

Installation Instructions for S100 Series Stainless Steel Passage Leversets on 63mm Round Rosettes

Step 1.

- Fold template where indicated.
- Position template on door edge at desired latch height.
- Firmly hold template and mark latch height and handle fixing holes at 60mm backset (refer template).
- Measure door thickness and mark centre.
- Drill 25mm (1") latch hole.

Note: it is important to drill this hole squarely.

- Drill one 50mm (2") hole or one 54mm (2 1/8") hole through door face at required backset as marked on template.

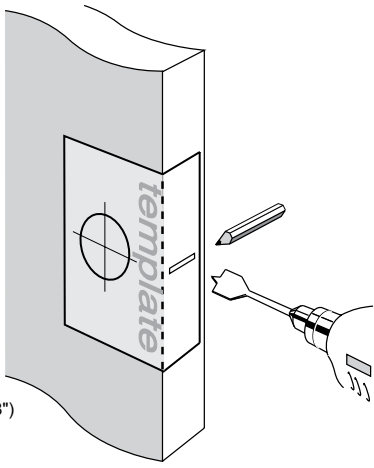

Step 2.

- Mark and chisel door edge for latch face plate to a recess of 2mm or until flush with door. Use latch face plate as a template.
- Pre-drill wood screw holes with suitable drill size
- Insert latch and fasten with wood screws provided.

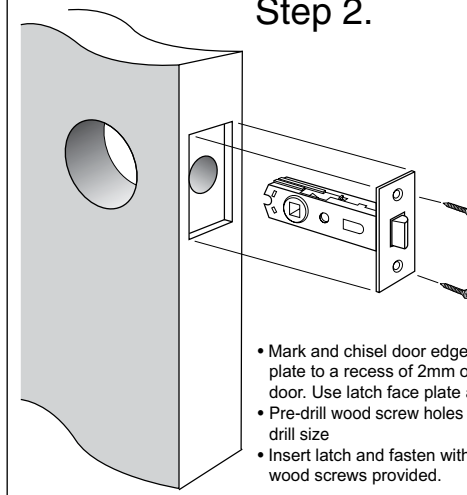

Step 3.

Install lever assemblies to door

- Insert square drive spindle (1) through latch in door.
- Identify which side of the door each lever assembly will need to be located in order to allow both levers to move in a downward motion once installed.
- Remove rosette covers (2) from both lever assemblies.
- Place one lever assembly (3) onto the square drive spindle.
- Place other lever assembly (4) into position, locating it onto the other end of spindle.
- Fasten both lever assemblies together with screws provided (5): Use long screws for thick doors and short screws for thin doors. Each under-rose features a countersunk hole and a threaded hole.
- Install one screw from either side, through the countersunk hole, through the latch and into the threaded hole of the opposite under-rose. Then tighten the screw head on each side.
- Tighten the grub screws (6) at base of levers on both sides with the hexagonal key (7) provided.
- Re-apply rosette covers (2) to both under-roses by pushing the covers over the rubber rings until flush with door.

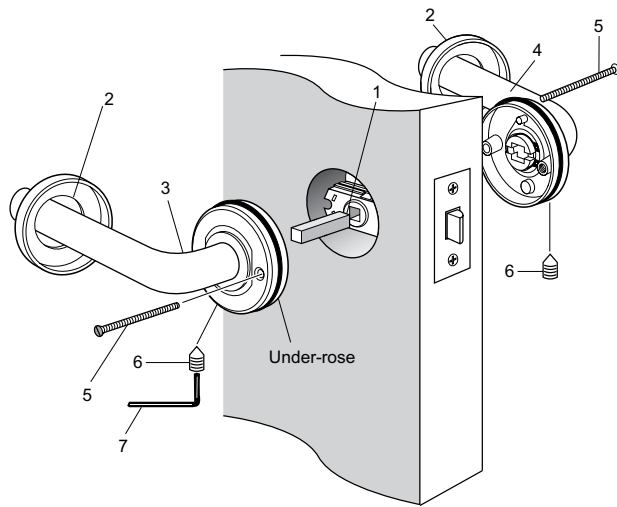

NOTE: Carefully follow these instructions when installing. Screws to be tightened to a recommended 2.5Nm torque.



Important Note

Only drill holes applicable to 60mm backset.
70mm backset privacy latch available separately – see your stockist.

FOLD HERE

Mark centre-line of latch hole

Mark centre-line of latch hole

Fit here on door edge

54mm (2 1/8") hole or drill 50mm (2") hole – refer Step 1.

BACKSET 60mm (2 3/8")

Fit here on door edge

Gainsborough
ENTER WITH STYLE™

Gainsborough Hardware Industries Limited,
Melbourne, Australia. A.B.N. 25 004 792 269
www.gainsboroughhardware.com.au

Suits doors 32mm (1 1/4") to 45mm (1 3/4") thick.

Installation template for passage applications